

The E-Class Cabriolet



Mercedes-Benz



This Brochure is prepared by Mercedes-Benz Group AG and it predominantly reflects the capabilities and performance of vehicles sold in Europe. Some characteristics, capabilities, performance features and optional extras (e.g. towing systems) may not be available or may not apply in Australia or under Australian conditions. The information in this Brochure is therefore indicative, illustrative and provided only for guidance and should not be relied on. To obtain current and accurate information on a vehicle and any options applicable to Australia, contact your local authorised Mercedes-Benz dealer.



Made to win the day.

In the lead, on the road as well. The new E-Class Cabriolet combines all the advantages of the Sedan model with the highlights of a sporty convertible. A puristic design with a focus on comfort and some sophisticated new features make your drive the sensuous highlight of the day.

Open to any challenge.

The all-season cabriolet combines maximum top-down comfort with the quiet of a Sedan. The automatic fabric acoustic soft top offers a unique level of noise insulation and thereby ensures relaxation without compromise.



Every successful day starts here.

Take control of the day. The steering wheel of the new E-Class Cabriolet has been completely redesigned and simplified. The wide digital cockpit provides you with an unrivalled overview of your trip.





Knows how to handle headwind.

No need to miss the advantages of a convertible even in low temperatures. The AIRSCARF neck-level heating wraps warm air around your neck and nape like a protective scarf. In addition, the AIRCAP draught-stop system automatically routes the airflow over the interior.

The image shows the interior of a Mercedes-Benz E-Class Cabriolet (convertible) with the top down. The focus is on the front passenger seat, which features a dark leather exterior and a light-colored, perforated leather interior with a quilted pattern. The driver's seat is also visible, showing a similar design. The dashboard and steering wheel are partially visible on the right side. A woman in a dark, professional outfit stands by the open driver's side door, looking towards the camera. The background shows a modern building with large glass windows and a clear sky, suggesting an urban setting.

Your entry to the business lounge.

Your personal wellness programme starts the moment you get in the new E-Class Cabriolet. ENERGIZING packages and ambient lighting can offer moments to take a deep breath or even a short revitalising workout. All of it is supported by the exclusive Burmester® surround sound system.

ENERGIZING Package optionally available.



MBUX.

Meet your personal assistant. The digital cockpit gives you access to all vehicle functions, information and even to the optional augmented reality mode for easy and intuitive navigation. Operate the new E-Class Cabriolet the way you prefer: via touchscreen, via voice command or via gesture control.

Carbon trim not available.



Augmented Reality Navigation is optionally available for all models.

MBUX Augmented Reality Navigation.

To enable you to find your way in complex traffic situations, MBUX Augmented Reality Navigation connects the virtual world with the real world. The technology incorporates graphical navigation instructions and traffic information into live images. So you reach your destination quickly, safely and stress-free.

All Multimedia, Connectivity and Software solutions (Applications and Data Content) contained within or associated with the vehicle are subject to terms and conditions. In some cases, the Applications and Data Content may be provided by third parties, not Mercedes-Benz Australia/Pacific Pty Ltd. Please refer to the relevant terms and conditions for more information including device compatibility, connectivity and capability requirements.



New MULTIBEAM LED headlamps.

The MULTIBEAM LED headlamps adapt to any driving situation. Thirty-six individually controlled LEDs mask out other road users and optimally illuminate every bend.

Light-alloy wheels in multi-spoke design.

Poise and assurance on the road. The modern rim designs give the new E-Class Cabriolet a pared-back, contemporary style.

Burmester® surround sound system.

Sound that speaks for itself. The Burmester® surround sound system combines high-performance loudspeakers and unique 3D acoustics into a legendary sound experience.

Standard for Mercedes-AMG E53 4MATIC+, optional for other models.

Ambient lighting.

Showcase the interior according to your personal preferences or current mood. The 64 colours of the ambient lighting create exciting colour schemes, which can alternate dynamically or illuminate several areas in different colours.

Carbon Trim not available.



A range of efficient and powerful 4 and 6-cylinder engines to choose from.

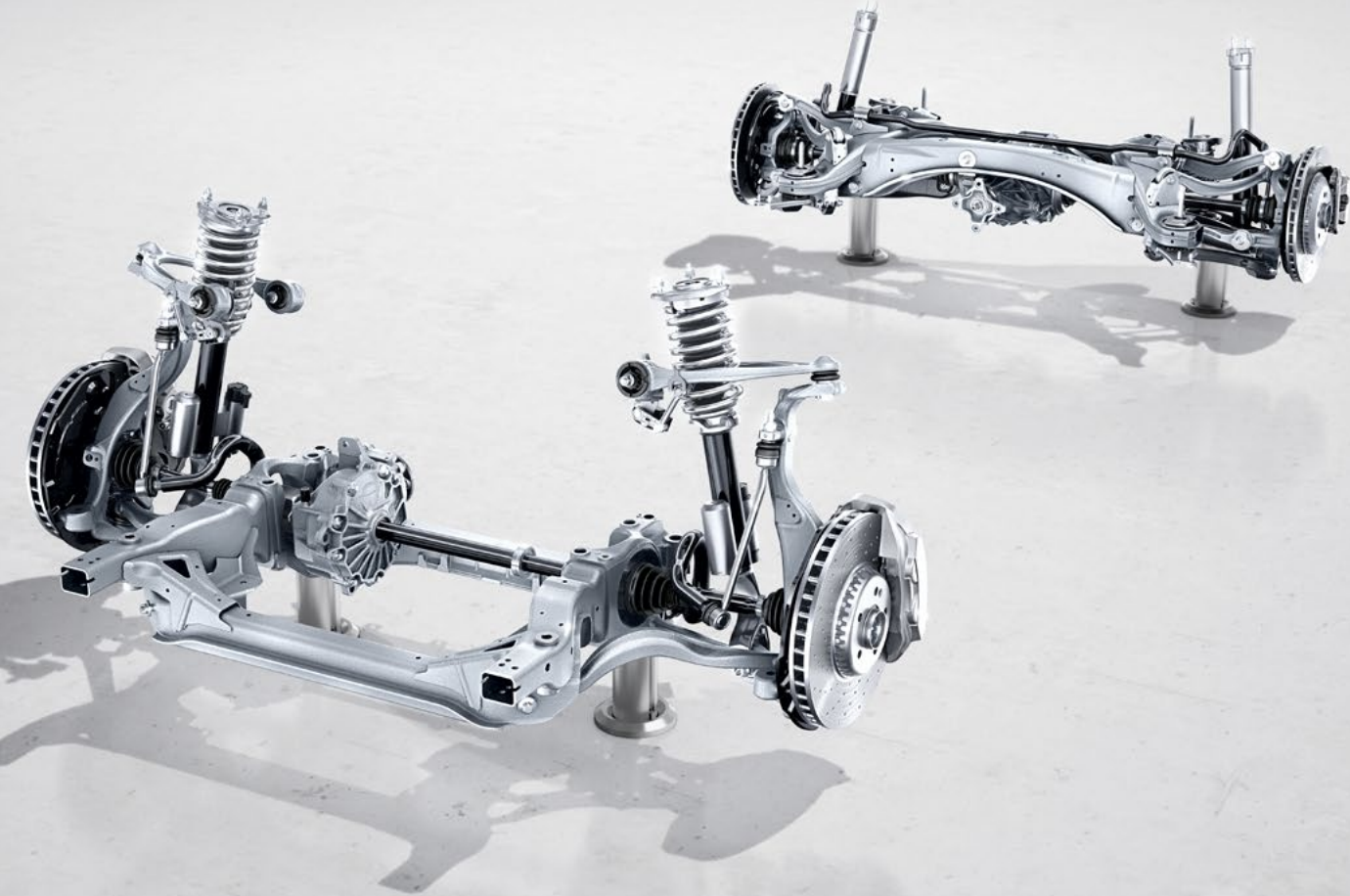

Choose your style of driving.

Tailor the new E-Class Cabriolet precisely to your preferences: The AIR BODY CONTROL air suspension system ensures comfortable motoring even on bumpy roads.

Made to win the night.

Every Mercedes-AMG is a masterpiece in its own right, with an unmistakable character. What unites our performance vehicles and sports cars is their irrepressible sporting spirit. Their passion for top performance. It's generated at the point where engineering skill meets a very special attitude: the spirit of AMG. We believe that you have to keep on challenging limits in order to achieve new goals. We accept nothing as a given. Because limits are imposed by people, and it's also people who can overcome them. It's this attitude that enables us to achieve outstanding performance for motor racing – and for the road.

Welcome to the world of AMG.

www.mercedes-amg.com

AMG
DRIVING PERFORMANCE



Technical data.

	Petrol engines	
	E 350	E 53 4MATIC+
Displacement (cc)	1991	2999
Rated output (kW [hp])	220 [299]	320 [435]
Acceleration from 0 to 100 km/h (s)	6.1	4.5
Fuel consumption ⁴ (l/100 km)		
Urban	10.5	12.1
Extra-urban	6.2	7.7
Combined	7.8	9.4
Combined CO ₂ emissions (g/km)	177	213

The best for the engine:
Mercedes-Benz genuine engine oils.

The declared fuel consumption figures are determined by testing under standardised laboratory conditions in accordance with ADR 81/02. The fuel consumption figures stated are for the purposes of comparison amongst vehicles tested under the same technical procedures only. Real world energy consumption figures may vary and are influenced by many additional factors such as, individual driving style, load, traffic, ambient temperature and vehicle condition.

Dimensions.

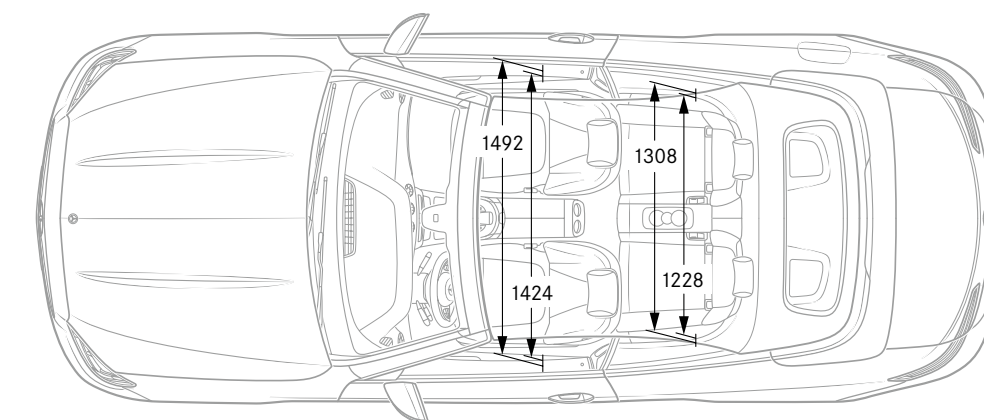
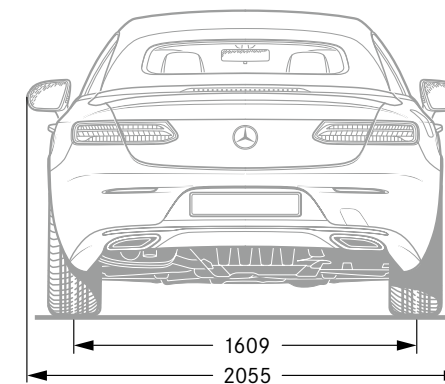
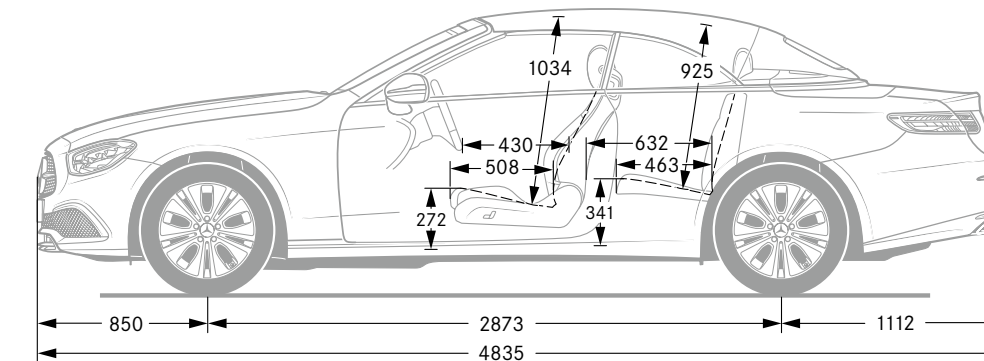
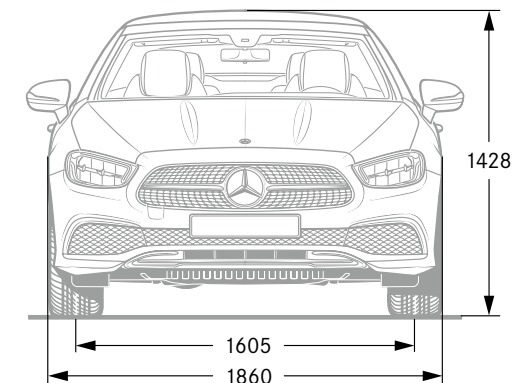

All figures in millimetres. The illustrated dimensions are mean values. They are valid for vehicles in basic specification and in unladen condition.



SPORT — F O R — GOOD

Mercedes-Benz AG is one of the founding partners of the worldwide “Laureus Sport for Good Foundation”, which was established in 2000. It is the Mercedes-Benz brand’s most important social initiative. Laureus Sport for Good supports children and young people in need through social sports projects, opening up new perspectives and imparting important values such as team spirit, respect and determination. “Change the Game for Kids” is our mission statement which we wish to share with you. In buying a Mercedes-Benz you are supporting the “Laureus Sport for Good” movement.

Please note: About the information in this publication: Changes may have been made to the product since the editorial deadline on 19.03.2020. The manufacturer reserves the right to make changes to the design, form, colour and the delivery scope during the delivery period, provided these changes, while taking into account the interests of the seller, can be deemed reasonable for the buyer. Where the seller or the manufacturer uses symbols or numbers to describe an order or the subject of an order, no rights may be derived solely from these. The illustrations may also show accessories and optional equipment, which are not part of the standard delivery scope. Therefore, please ask your Mercedes-Benz sales representative about the provisions and effects applicable in other countries and about the latest definitive version. www.mercedes-benz.com.au