



CSR 762







- > CSR: Backstory
- > Design Inspiration
- > The Aerodynamics
- > Ergonomics
- > PMS Motor
- > Display
- > Skeleton Chassis Frame

- > EV Package
- > Battery Swapping Technology
- > After Sales
- > Accessories
- > Digital Experience
- > Service & Maintenance
- > Finance





## **THE STORY BEHIND**

Starting with our journey as Pioneers of Electric Cycle Industry in India, Before unveiling our EV bike - **CSR 762**, the Switch Group of Companies had already carved a niche in the electric bicycle segment. Building on our success and driven by a passion for sustainable mobility, we now venture into the electric bike segment. Fueled by the power, passion and pride of our visionary Founder **Mr. Rajkumar Patel**, our EV bike is an outcome of forward-thinking vision and commitment to a sustainable future. With the desire to redefine urban mobility, we embarked on a journey to create an electric vehicle that seamlessly blends cutting-edge technology with powerful design. Our mission is to empower consumers to commute with a clean, efficient and exhilarating way to navigate the streets.

---







## **ZOOP PAST ANY ROAD SEAMLESSLY**

We present our excellence with CSR 762 Electric bikes. When you're in the mood for some excitement, go off-road and ride with your heart. You can also effortlessly maneuver through dense traffic and the city commute with the CSR 762 electric bike. For the foreseeable future, this next-generation technology will change the EV automotive business. Get creative with the bike as we encourage you to ride according to your moods and unfurl the varied contents of your character.

# INTRODUCING THE FUTURE OF URBAN MOBILITY

For the longest time possible, the automobile segment has been going back and forth with sustainable and safe mode of transportation.

CSR 762 offer consumers the luxury with sustainability. The CSR 762 Electric Bike is the epitome of urban sophistication, blending cutting-edge technology with the powerful design to revolutionize the way you navigate city streets without making a hole in your pocket.







Boot Door

Boot Space

# READY TO RUMBLE

The specs create a very indigenously designed superbike that makes the most justified claim of transforming itself an aura that leaves you with an impression of riding supra-natural badass that makes you want more & more. Replacing the I.C. engine with an Electric PMS Motor has to be the boldest decision yet.

For far too long, rising petrol prices have been dictating the motorcycling behavior of two-wheeled commuters. Now that the petrol dynamic is out of the picture, people can ride as per their mood.

We're ready to rumble with all the necessary accessories & apparatus equipped to smoothen your motorcycling experience. The bike has a decent spacious provision to contain the rider's helmet & the necessary stuff an Indian Layman usually carries.

Everything is easily available & accessible before the riding experience even starts. The bike is guaranteed to add a bit of flare to your dynamic personality. Right accessories for the right person, is what we say.

The EV package controls to manage all riding phases, from the start to acceleration, braking, traction, through the corners, and out the other side.

The controls can be adjusted by the rider and combined with 5 riding modes (1 Reverse mode, 1 Sports Mode & 3 Standard riding modes)

It will include the latest version of the PMS motor along with the central drive system, a bike that is effective on roads. The perfect city commute.

Visible precision finishing of Red, Black, Grey gives life, charisma & enigma to the EV Motorbike, CSR 762.





## DESIGN INSPIRATION

A true representation of pride, strength and individuality is the lion. Most significantly, the lion is an ideal representation of our company since it embodies our aim to dominate the automotive market through the production of innovative and clean products.

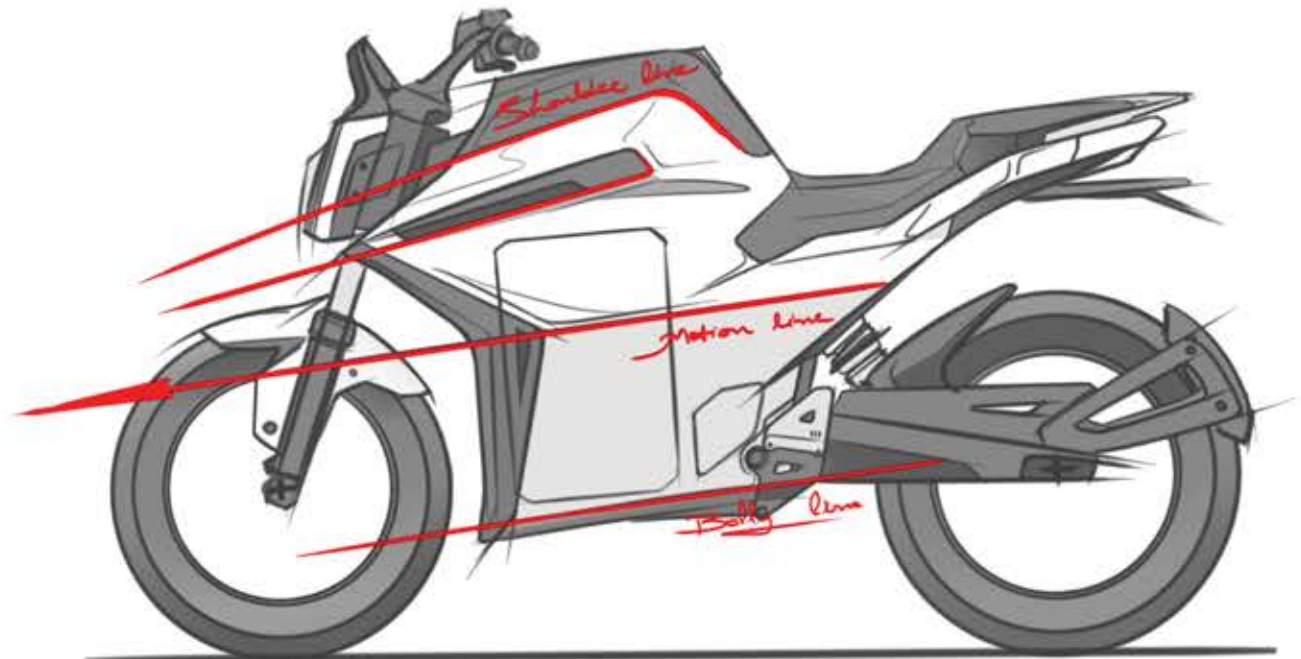
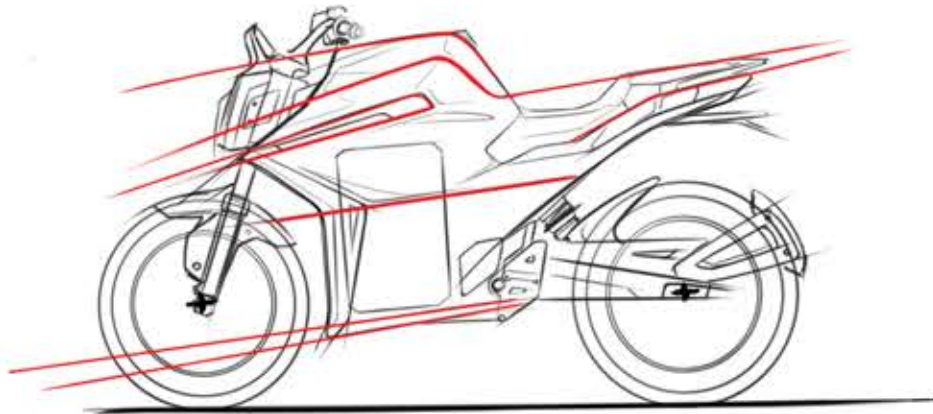
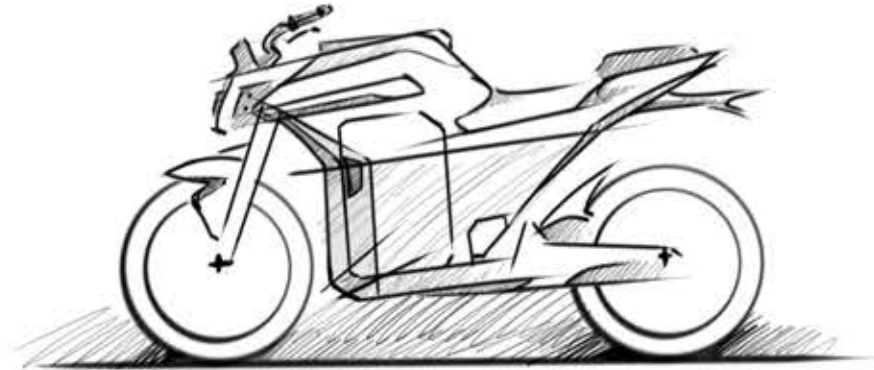

Character lines





## **THE HEADLIGHT ASSEMBLY**

The minimalist full LED headlight perfectly captures the spirit of CSR 762. The bike takes its design inspiration from the majestic Asiatic lions found in Gujarat embodying the spirit of pride, personality & power.

The full LED headlight assembly, part of the dual tone fairing adorned by a chrome ring, has a particular design that allows it to incorporate the air-box and LED cooling vents. The headlight is surmounted by a 5" TFT display, complete with a sophisticated front cover that elegantly conceals attachments and wiring.



## **AESTHETICS OVERVIEW**

The bold and powerful CSR 762 comes in three sleek hues: Diamond Black, Scarlet Red & Dark Tungsten .

It's electrifying, trendy and aggressive color scheme flaunts the "badass" side of the CSR 762 and attracts attention while riding it.

There is a special provision of holding & carrying two battery suitcases as the waterproof battery carrier box modular can carry two battery suitcases at a time. The battery e-case comes in a suitcase style packaging which adds a layer of sophistication to cater to the sophisticated millennials.

The bike will add personality to your character & vice-versa. Be the centre of attention on every road so better get used to it! Kick back your embarrassment by riding one of the best bikes there is.



## FUSELAGE

# AVIATION INSPIRED COOLING TECHNOLOGY & DRAG CONTROL

Fast, agile & mixed-road performance demands maximum stability at high speed and also while braking.

So, this leads to reduced wheel-up during acceleration which minimizes electrical control of the vehicle. Hence, CSR 762 has together the PMS motor & Central Drive System.

The calculative approach involves stationary simulation of flow and pressure to achieve increased intake, especially during cruising.

To reduce lateral protrusion as much as possible, the aerodynamics team decided to adopt a configuration of maximum comfort to withstand the mean roads of India full of potholes.

Moreover, the cooling vents have been positioned close to both the battery & motor controller to prevent overheating, which has been a fundamental issue with EVs.

CSR 762 technology plans to take that obstacle head-on. The aviation-inspired cooling technology ensures maximum stability on the uneven roads of India perfectly suited for the layman as per their regular commute from their office to home, increasing the life span of EV components & the performance during high speed, also to reduce the maintenance cost.







ERGONOMICS

## **GREATER CONTROL AND COMFORT**

Ergonomics in automobiles can be defined as the optimal adaptation of a vehicle to the people using it. This minimizes the strain, increases comfort, and ensures the safety of both the driver and the pillion. The CSR 762 Electric Bike redefines the standard for ergonomic excellence in the electric bike industry. With respect to CSR 762, the rider's seat is positioned at 810 mm from the ground to deliver a seamless motorbiking experience. The handlebar is high, wide & together with a less extreme rider footpeg position which offers sports grade comfort & experience during the inner-city rides. The lower part of the boot space has been modified to allow for the mounting of a seat with extra cushion, to further increase rider comfort. In addition, the tail has been redesigned.

Supported by a steel subframe, it retains many of the style features while also offering the passenger greater comfort and the rider more room lengthways. We are not just offering a product but introducing a transformative and ergonomic riding experience.







HIGHER EFFICIENCY

## **AN EXTRAORDINARY PMS DC MOTOR**

Moving on to the Permanent Magnet Synchronous Motor, it can be seen as an AC counterpart of the Brushless DC motor.

PMSM also comprises a Permanent Magnet as a Rotor and a Stator with a Coil wound over it. The working of PMSM is also quite similar to the BLDC motor.

However, the change lies in the wave form of the Back EMF which is sinusoidal in nature. PMSM has been the latest break-through in the EV industry in terms of producing efficient & seamless motors which deliver the premium motorcycling experience that you deserve.

It also implies that PMSM requires Alternating Current to achieve the best performance. This type of drive current also reduces the noise produced by the motor.

One of the advantages of the PMSM is the absence of Torque ripple, which makes these motors more efficient at low speed otherwise known as Servo Mechanism in Automobiles.

Servomechanisms are a set of motors and motor controllers that produce motion at a higher energy level than the input applied. PMSM are the first choice of Motors to support such a mechanism. This is because PMSM are highly efficient, quieter, and are resistant to wear and tear.

One example is the servo brake that amplifies the force used by the driver on the brake pedals. Another example is the Servo Steering which is one step ahead of the regular power steering. This also makes use of a PMSM. Even in the Electric Vehicle Drivetrain PMSM is the preferred choice. Reasons are high power density and the availability of efficient control solutions.

The ability to work on high speed and inherent durability, make PMSM the preferred choice for application in Urban Commute. A sensor-based PMSM can detect the position of the rotor and apply optimum torque to drive.

CHASSIS:

## **DESIGNED FOR DURABILITY**

CSR 762 flaunts a Skeleton Chassis Frame (SCF) which embodies what it stands for: Perseverance when the terrains rain down hell on you.

The CSR 762 packs in a powerful 3kW Motor that peaks up to 10kW at 3800 RPM which is packed by a PMS motor with a central chain drive system supported by the Li-ion, nickel-manganese-cobalt(NMC) battery ranging up to 3.6kWh The top speed of the bike goes as high as 120KM/h and the bike can go as far as 160 km on a single charge depending upon the many modes that come with the bike.

The wheelbase boasts 1430 mm & the kerb weight along with the weight capacity go 155 kg & 200 kg respectively. The rake angle is 24 degrees & the trail of 136mm.

The saddle height is 810 mm which flaunts 5 riding modes: 3 riding modes, 1 reverse mode & 1 sports mode.

The main advantage of this solution is that it uses the motor to achieve the desired stiffness, which has resulted in significantly lower main frame length and a better stiffness/weight ratio.



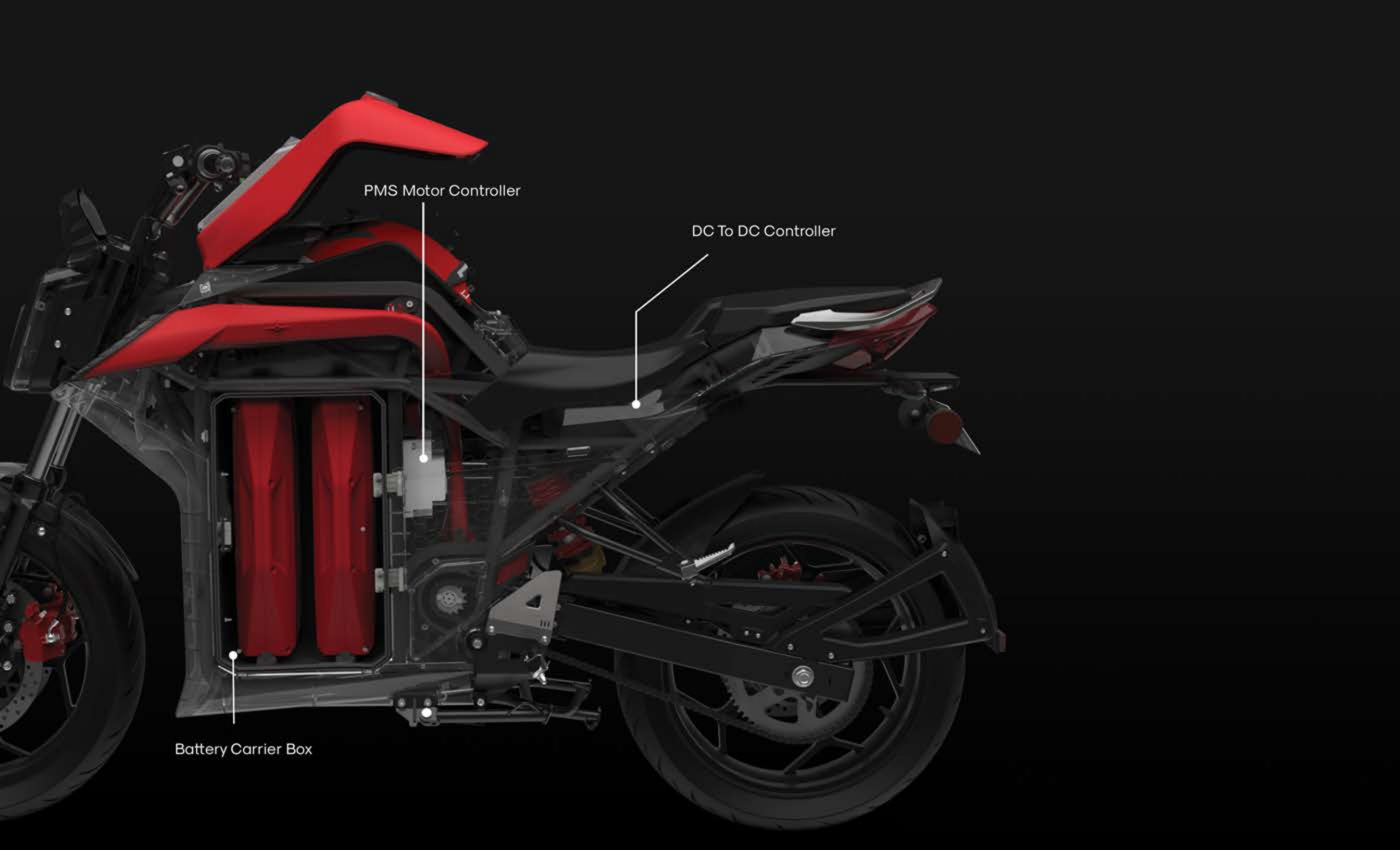

PMS Motor Controller

DC To DC Controller

Battery Carrier Box



**INDIA'S COOLEST  
ELECTRIC BIKE!**



# RIDING MODES

There are 5 modes & a bonus Parking mode in the CSR 762

3 Standard Modes for normal urban city commute in increasing order

**Reverse mode**, to assist you through the tricky roads of the Indian Demographic.

**Sports mode**, for when you're feeling the thrill to hit the road head-on.

**Park mode**, especially for when you're parking the vehicle which does the job in minimum battery wastage.

Go for a spin without having to worry about battery consumption.

Riding Modes provide users with three different pre-set riding styles so that CSR 762 performance can be adapted to the rider, road type, and weather conditions. Changing the Riding Modes instantaneously changes the character of the motor, the electronic control parameters. Riders can personalize settings to suit their riding style or restore the default parameters, which acts on the front wheel only to allow maximum braking performance.

The EV motorbike offers multiple riding mode options to the rider. The 3 standard modes in increasing order offer a range to the rider when riding inside the prime traffic hours of the city. Three standard modes come in handy when one has to cruise around the city at the convenience. The bike can go around 160kms (depend on the mode) on a single charge and can go as high as 120 km/h.





## **RIDING MODE KNOB**

CSR 762's Riding Mode Nob features a 5" TFT display. It displays the riding modes, speed, range, and battery information. The LED lights show the shades of red color & as the RPM increases the light turns red.







"Preachers only preach the rules, it's the winners who decide the rules."

CSR 762 follows a similar ideological trajectory when it comes to the display. It flaunts all the necessary information with utmost class & precision.

The idea is to not distract the motorist while riding by beaming out bright lights but rather to subliminally convey all the necessary information with a velvet touch of subtlety.



x10A  
x5A



## **EASY TO USE, GOOD TO LOOK AT**

The latest generation 5" TFT Display on the CSR 762 is an all-around package with controls to manage every riding phase. In addition, the operating parameters of each control are associated by default with respect to all the 5 riding modes.

Riders can therefore personalize their riding style as per the road conditions, weather, or ride on the default settings.

However, it is not advised to ride the bike in extreme heat or leave the bike parked in the heat. Make sure the bike is parked in a cool shade, and not overcharged in order to assure a seamless riding experience.

All the 5 riding modes can be accessed by using the function key. The display will showcase the speed in km/h, the Odometer showcasing the range as per the battery juice availability, RPM, Voltage of Motor & battery information.

The battery information is depicted in 10 bars with 10 being the highest & 1 being the lowest. As the bike is ridden, the battery bars reduce, and as soon as 1 bar is shown, it goes red hence indicating a low battery & the battery needs to be replaced with a fresh one.

# ULTIMATE THROTTLE RESPONSE

The latest generation EV package packs in a continuous power of 3 kW with the peak power going as high as 10 kW for the Motor. In terms of the Controller, the continuous current is 100A, which is regenerated by the controller. These modern specifications add a layer of finesse to this new-gen electric motorbike.

Riders can therefore personalize their riding style or restore the factory settings. Any of the control levels can be quickly adjusted via the function key.

CSR 762 follows the mantra of, "Float like a Cadillac, Sting like a Beemer", hence it ascends past the requisites to deliver the speed that you need at the palm of your hands.





This will save a lot of battery juice as this prevents wastage. The company Switch Smart Solutions will provide all the necessary infrastructure required to charge & maintain all the apparatus with regards to the infrastructure provided by Switch Smart Solutions.

CSR 762 offers the complete on-road experience keeping in sync all the needs & wants of the Indian layman by offering the state of the art design & cutting edge technology without burning a hole in their pockets.



Mobile Phone Holder

## **CENTRAL SMARTPHONE HOLDING CAVITY**

The mobile cavity slot gives the provision in the CSR 762 to keep your mobile devices securely along with giving a USB cable for your mobile devices to charge.

The intelligently designed cavity seamlessly guides the rider to commute hassle-free and have the ultimate riding experience.

## POWERING JOURNEYS

The PMS Motor & the Central Drive System, of the CSR 762 boasts a very powerful 3kW, 72V which will equip you to rule the roads. Ride carefree without having any second thoughts about the ever-increasing fuel prices.

The DC PMS Motor delivers 56NM, 240NM of Torque at 3800 rpm respectively. This ensures a more effective anti-hopping function but also reproduces the characteristic sound that all city commuters appreciate.

The motor is more or less evenly loaded at its maximum capacity utilization. Experience the force that propels your ride to new heights. Brace yourself for an electrifying journey as this motor is not just powerful but commands the road with authority.

Experience the unwavering force and redefine the biking performance, serving as a benchmark for power-driven rides. Redefine dominance through the pinnacle of control and potency, exemplifying a new standard for high performance journeys.







## WELL POSITIONED FOOTPEG

Thanks to its functional equipment, the CSR 762 is the ideal companion for the amateur who wants to rule the Indian roads with an Electric Bike and get an instant response. Boasting extraordinary braking power, the bike is easier to lay into the corners and reaches the apex quicker, while also ensuring excellent stability at high speeds. The foot pegs are placed in a such way that they are easily reachable as per the average Indian height and structure.

## BRAKING SYSTEM\*

The braking system consists of the Front 300 mm disc brake and Rear 280mm disc brake and 2 piston calipers.





## **YOUR JOURNEY. YOUR CONTROL**

The design of the adjustable foot pegs add to that all-important level of interactions between rider and the bike, by allowing for the ideal riding position. Highlighting the attention to detail, the footpegs are produced with high-quality rubber & cast iron (CI) which maintains its original appearance over the time, and are equipped with heel guards and jointed brake to minimize the risk of breakage in case of a fall.

Last but not least, the foot pegs are designed to be stationary. CSR 762 remains unaltered even when the terrains rain down hell upon you. Feel the confidence in every step you take and the control with every brake you make.







FEEL THE POWER IN YOUR HANDS

# THE CSR 762 BADGE 3KW POWER UNIT

Injecting the CSR 762 with its soul, sound, and speed is the PMS DC motor along with the central chain drive system. With its 24° rake layout, it boasts the complete city riding experience. And if this was not already enough the PMS motor leaves no stone unturned to offer the urban commute within the city limits. It delivers 3800 rpm and maximum torque (Motor/Wheel) of 56 NM/240 NM at 3800 rpm.

For ultimate control on road, even during the most aggressive downshifting, the 24° rake of the CSR 762 offers a seamless experience, on & off the road.

The new clutch also guarantees greater smoothness during all "off-throttle" phases, as well as the possibility to customize the level of "mechanical" motor brake, by selecting a different modes available as per the different riding modes. Take the bike out for a spin, or ride to your office or college; CSR 762 is a guaranteed head-turner.



## THE STATE OF THE ART **BATTERY SWAPPING TECH**

The CSR 762 will come with the battery swapping technology in phase 2 as one will be able to replace their bike's batteries once they run out of juice. This empowers you with flexibility to eliminate the hassle of charging batteries during longer journeys.

Swap your batteries swiftly, keep the momentum going and embrace the ride that is as dynamic as you are.

Focus on the thrill of the ride, not the charging pit stops.





762

CSR 762

CSR 762





# FINANCE

There are various financing options when it comes to CSR 762. The ballpark price figure of the bike is slated to be around INR 1.65\* Lakhs with a tentative subsidy of upto INR 40K\* from the Government of India. Along with that, the Government is also looking forward to bringing-in a Battery Swappable Policy which will further subsidize & incentivize the whole initiative. The company looks forward to keeping a similar price model across India to maintain uniformity & enforce the culture of the brand.

There are various financing options available if one is looking to get their hands on the bike. From EMI to digital payments, we've got you covered. There is also an option of availing dealership & distributorship of the bike if one is interested. Since the owner & the man behind the whole endeavor, Mr. Raj Patel has put in their very own money, internalizing the concept of a bootstrap.

# SERVICE & MAINTENANCE

## SAFETY AS STANDARD

CSR 762's continuing commitment to design, research, and development has the precise objective of guaranteeing state-of-the-art motorcycles characterized by the highest degree of active safety. It is made with city commute in mind and a view to increasing the level of control during the most difficult riding that we continue to develop systems that are always at the forefront of safety and performance. The system controls every moment of braking even when the bike is leaning, the system kicks in to fine-tune the braking torque. These systems allow the rider to enjoy, in complete safety, the maximum performance of the bike.

## MORE VALUE TO YOUR PASSION

The quality and reliability of the CSR 762 brand remain your inseparable traveling companions over time. CSR is built on the fundamentals to equip the mass of Indian demographic with the most luxurious as well as cost effective EV two wheeler experience. It aims to solve the issue of last-mile mobility with the utmost creativity & premium riding experience. Especially at a time when petrol/diesel two-wheelers are not reliable for the average Indian pocket.

Opting for a CSR 762 guarantees worry-free travel and absolute freedom, allowing you to explore any road with confidence. Rest assured with the backing of our extensive Dealer network, committed to providing quality and professionalism for your journey.

## ENDLESS EXCITEMENT

In designing each bike, CSR 762 constantly strives to ensure maximum reliability while reducing service costs. To ensure that the excitement stays intact, make sure you go over these safety & security guidelines. Don't park the bike in the direct throw of sunlight, park in a shade, garage, or preferably in a basement. Avoid riding in the primetime summer as it may use up the battery cells faster than usual. Don't overcharge the bike. Take good care of the battery. In case of any doubt or confusion, reach out to your nearest CSR 762 dealers or the Switch MotoCorp Service Team.

A considerable interval for such high-performance motors, which only confirms the high-quality standards adopted in terms of material selection and R&D processes.

CSR 762 consistently dedicates resources to enhance the technical expertise of its dealers. The exclusive skills provided by the official CSR 762 Service network guarantee the meticulous execution of all essential operations to maintain each bike in optimal condition. Advanced equipment on every electric bike is regularly updated with the latest releases, ensuring that the electronics consistently deliver peak performance.

#### ALWAYS BY YOUR SIDE

One of CSR 762's main goals is to offer every rider the chance to enjoy unlimited and safe travel all over the world. The sister company of Svitch MotoCorp pvt. Ltd. (CSR 762), Svitch Energy Pvt. Ltd. has a very strong base of 125+ Dealers & Distributors across Pan-India. So, the riders of CSR 762 can experience the goodwill & premium Svitch service. Embark on carefree rides and immerse yourself in a dynamic motorcycling adventure.



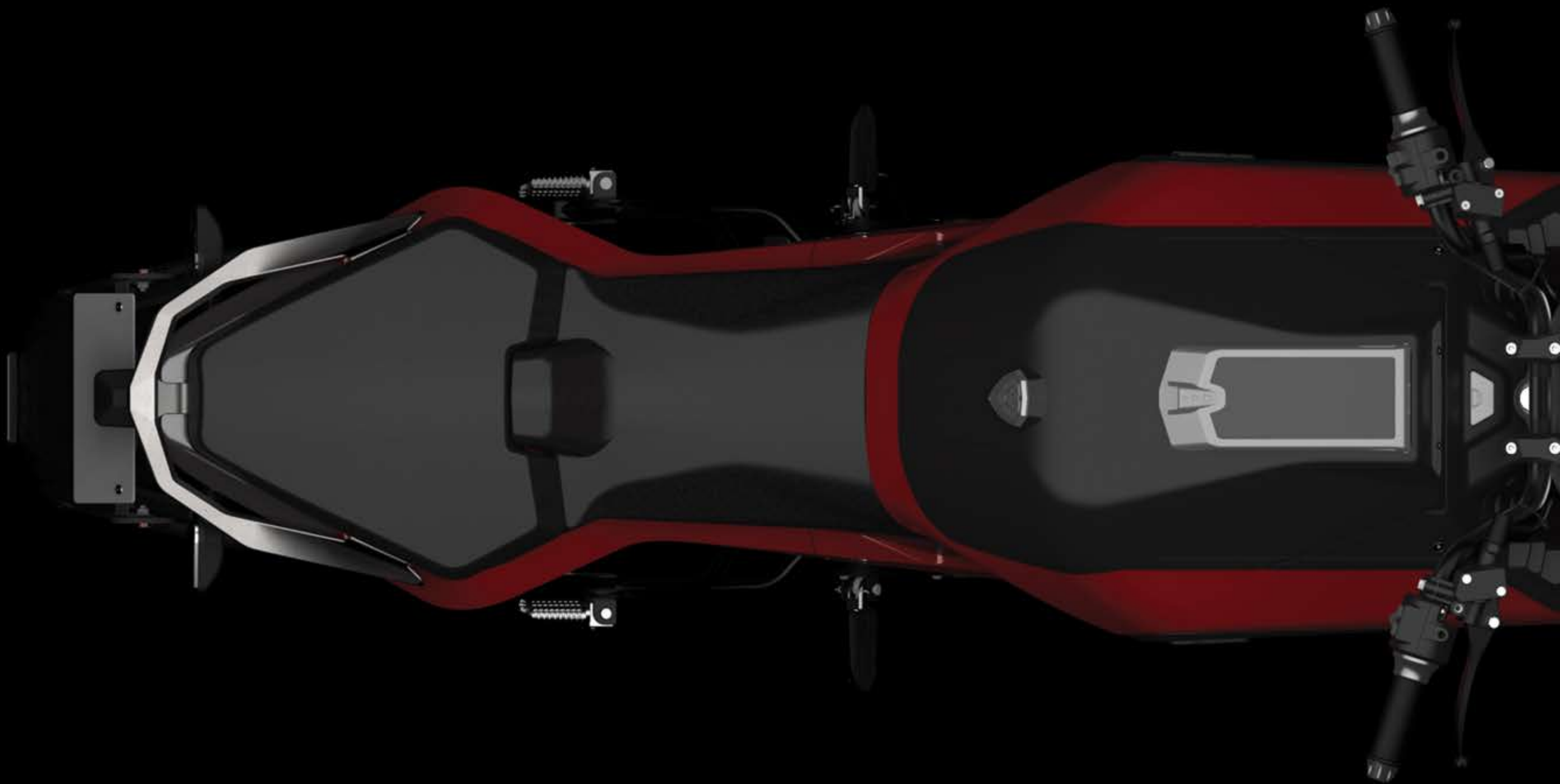

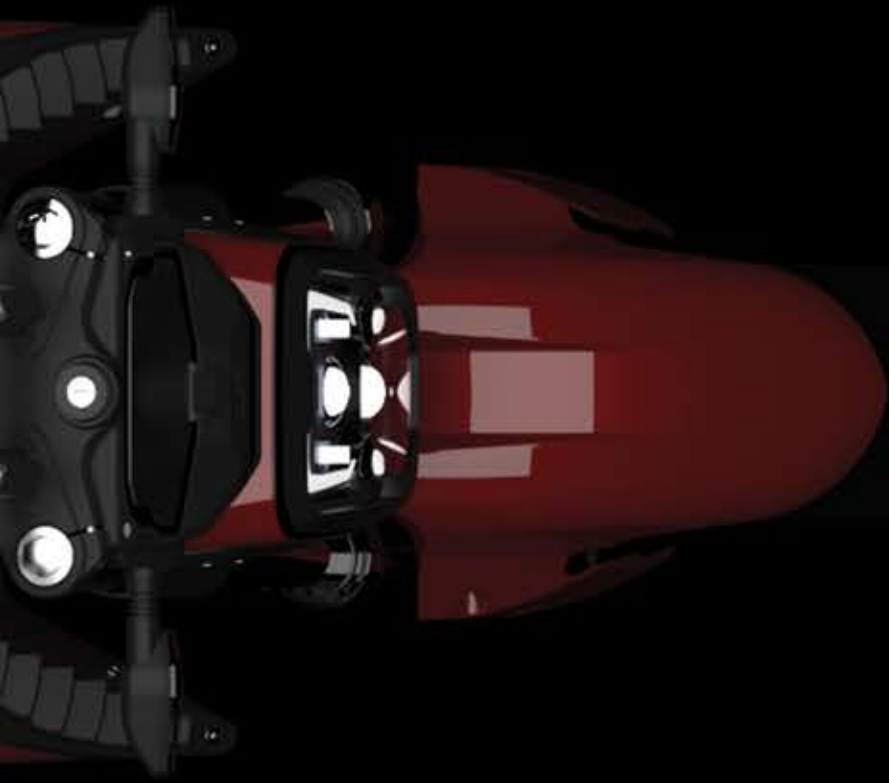

**JUST WHEN YOU THOUGHT  
YOU HAD IT ALL FIGURED  
OUT ABOUT EVS,  
WE CHANGE THE CULTURE.**

# CSR 762

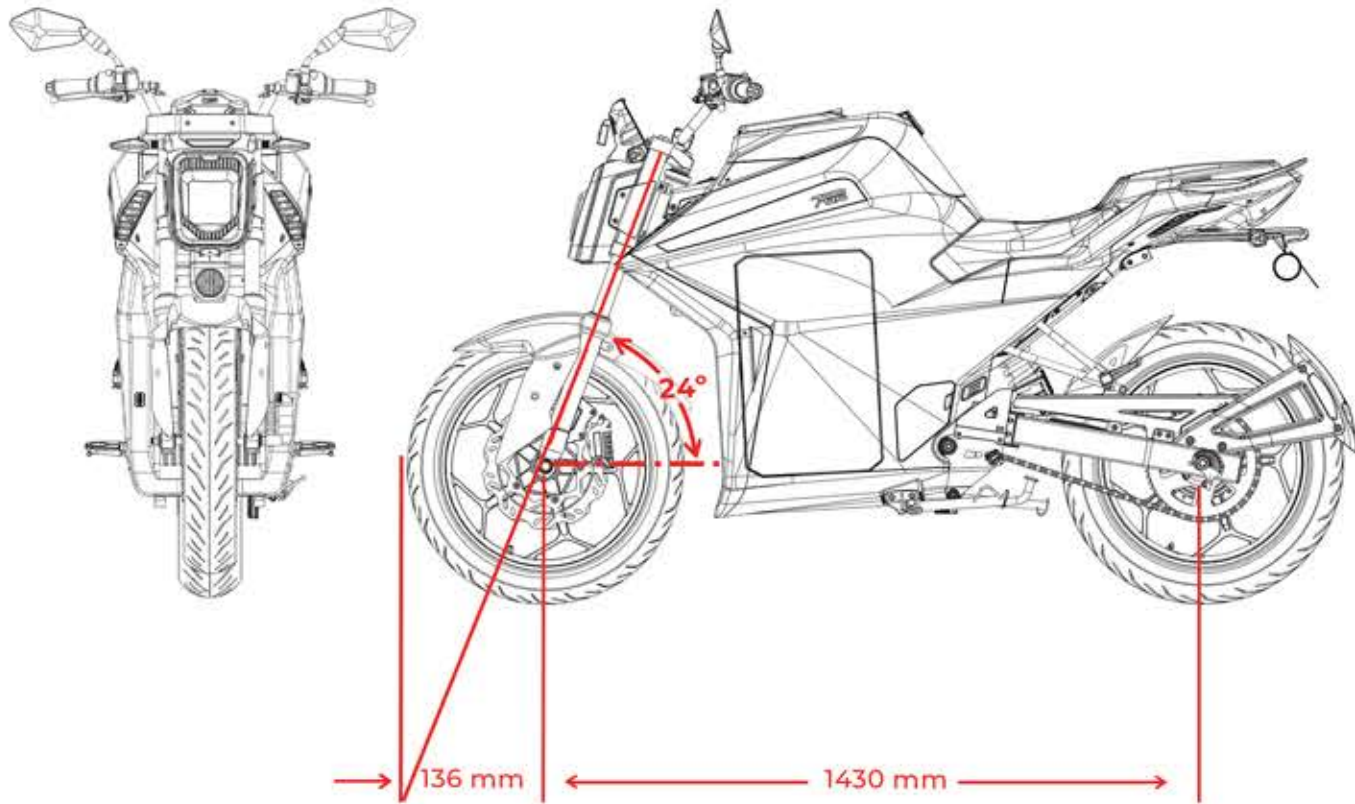

## GENERAL SPECIFICATIONS

NOMINAL POWER	3kW
PEAK POWER	10kW @3800 RPM
TORQUE (MOTOR/WHEEL)	56 NM/240 NM
TYPE	PMSM, 72V DC (CENTRAL DRIVE)
TOP SPEED	110KM/h
RANGE	160 km (depends on modes)
WHEELBASE	1430 mm
KERB WEIGHT	155 kg
WEIGHT CAPACITY	200 kg
RAKE	24°
TRAIL	136mm
SEAT HEIGHT	810mm
RIDING MODES	5
TRANSMISSION	Chain drive (1:4.3)
RIMS	17"
MOTOR	Mid drive (PMSM)
RATED TORQUE	56 NM without reduction rated
TYRES	Tubeless Front 110/80 Rear 140/70
BRAKES	Combi-brake Front (300mm disc brake) Rear (280mm disc brake)
SUSPENSION	Front (telescopic) Rear (monoshock)
CHASSIS	Carbon steel skeleton frame



## FEATURES

BATTERY	3.6kWh
BATTERY TYPE	Lithium-Ion
BATTERY SWAPPING	✓
CARGO SPACE	40 L
CELLPHONE HOLDER + CHARGING	✓
SMART CONNECT	iOS and Android Smartphone APP
INBUILT PORT INSIDE BOOT	Type-c, USB 3.1 x 2
REGENERATIVE BRAKE	✓
ELECTRICAL MALFUNCTION PROTECTION	✓

## BATTERY

NO. OF BATTERY	2
BATTERY BALANCING	✓
WEIGHT	10kg
BATTERY CAPACITY	3.6 kWh
BATTERY CHEMISTRY	Li-ion, Nickel-Manganese-Cobalt (NMC)
ACTIVE THERMAL MANAGEMENT	✓
PROTECTION CLASS	IP67
CHARGING CYCLE	>1500

CONFIGURE THE CSR 762 OF YOUR DREAMS

# **IT'S A CULMINATION OF PRIDE, POWER & PERSONALITY.**

The new-gen CSR 762 aims to align & transform the usual vanilla two-wheeler automobile market towards accepting EVs as a serious mode of commute with CSR 762 being at the forefront of the change. The Indian market is finally coming to terms with the fact that petrol/diesel aren't just gonna cut it. EV is the future and there are no two ways about it.

With the climate change and deteriorating health of the planet, there is no other option but to go electric. This is where CSR 762 comes in. CSR 762 aims to replace urban modern city commute completely by carving out a niche of its own.

Riding a motorcycle is the most exciting way to enjoy the road, and offering the utmost safety to the motorcyclist is CSR 762's commitment. CSR 762 bikes are increasingly easy to handle, reliable, and better equipped to guarantee maximum safety and enhanced riding pleasure. Technical clothing is made with more and more advanced materials for adequate protection and increased visibility.

The aerodynamics thus instill confidence and limit the intervention of the electronic controls. This helps the rider keep the throttle open longer and brake later going into the bends, resulting in significant performance benefits.









CSR INGENIOUS CONTROLLER



SVITCH E-CASE











The traditional long journey motorists often argue that they don't get the same feel & experience in EVs because they're calmer, quieter, cost-saving, gearless & fundamentally unconventional. Who'd have thought that people would actually drop petrol/diesel as a serious mode of commute and would actually shift gears to EVs? Well, that's the thing about time, it changes.

The cycle goes on. We all move on. Whoever is the most adaptable, survives. Hence, survival of the fittest. CSR 762 not only aims to craft a niche of its own but it aims to help in the smooth & seamless transition of people from petrol to Electric: one step at a time. It doesn't ask anyone to take a blind leap of faith but to take a conscious, calculated risk.

Biking is all about experience and the new-gen CSR 762 is here to fulfill all of it by equipping its riders with the latest, most modern technology there is. Along with providing battery swapping stations.

There are also talks to install a personal battery swapping station for every rider who buys the bike. So, CSR 762 isn't just a bike, it's a hurricane of revolution.







### **WHAT ONE CAN EXPECT?**

With the undying commitment of the entire CSR 762's Design - Development team and the vision of the Founder - Mr. Rajkumar Patel, CSR 762 is the epitome of riding comfort, throttle response, user experience, battery range improvement & most importantly safety to comply with the mandatory norms. The electric drive system offers seamless torque delivery at lower speeds to improve the climbing capabilities of the vehicle.



In conclusion and in all fairness, CSR 762 isn't just a bike. It's a complete electric vehicle experience and revolution. Battery swapping feature, state-of-the-art tech all packed in a riding experience that will leave no stone unturned to transform the bounds of EV automobiles in India & overseas alike. The bike has been in the pipeline for a while , and after multiple prototypes which were overlooked by the MD & CEO, CSR 762 is now ready to rumble on the city streets.

Not just stopping at CSR 762, we have a lot more in the store for everyone in the pipeline. After developing a stronghold over India, CSR 762 aims to target the Global market as well.

Passion often breeds out of the most ambitious of the places as the CSR 762 embodies the spirit of Pride, Power & Personality. Standing its ground uncompromisingly even when the terrains rain down hell. We stick by our tagline "More power to you" - for us it is not just saying, it is a philosophy. The philosophy that we stick by to empower the mass with amplified riding experience.











# **CSR COLOUR PALETTE**

**SCARLET RED**







**BLACK DIAMOND**



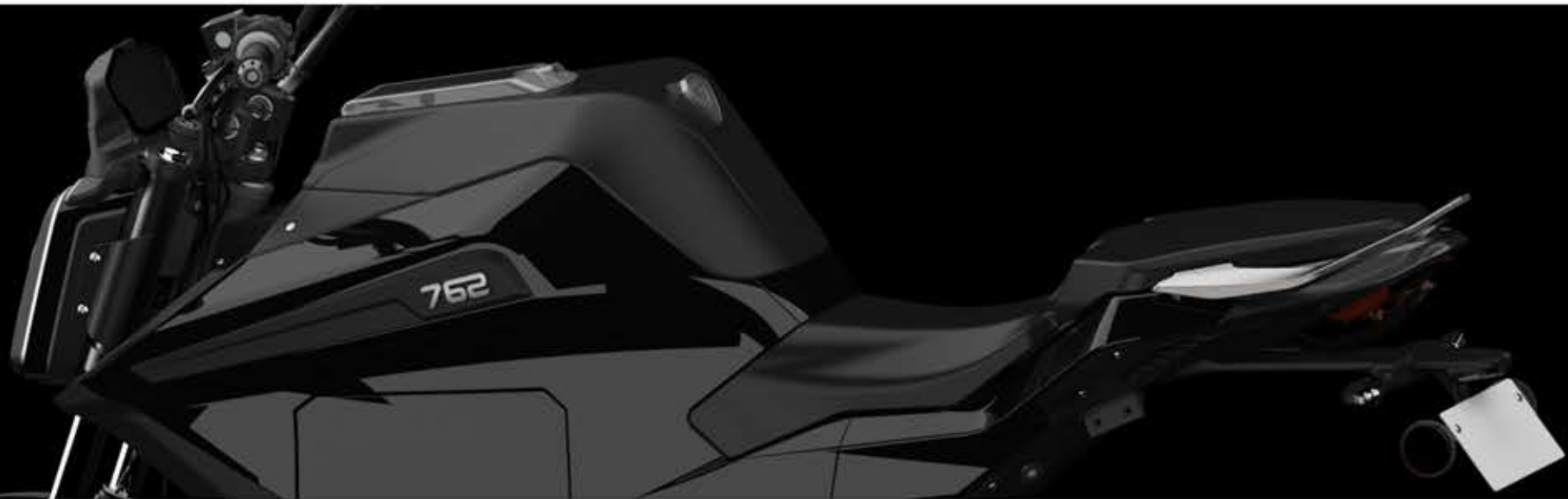





**MOLTEN MERCURY**



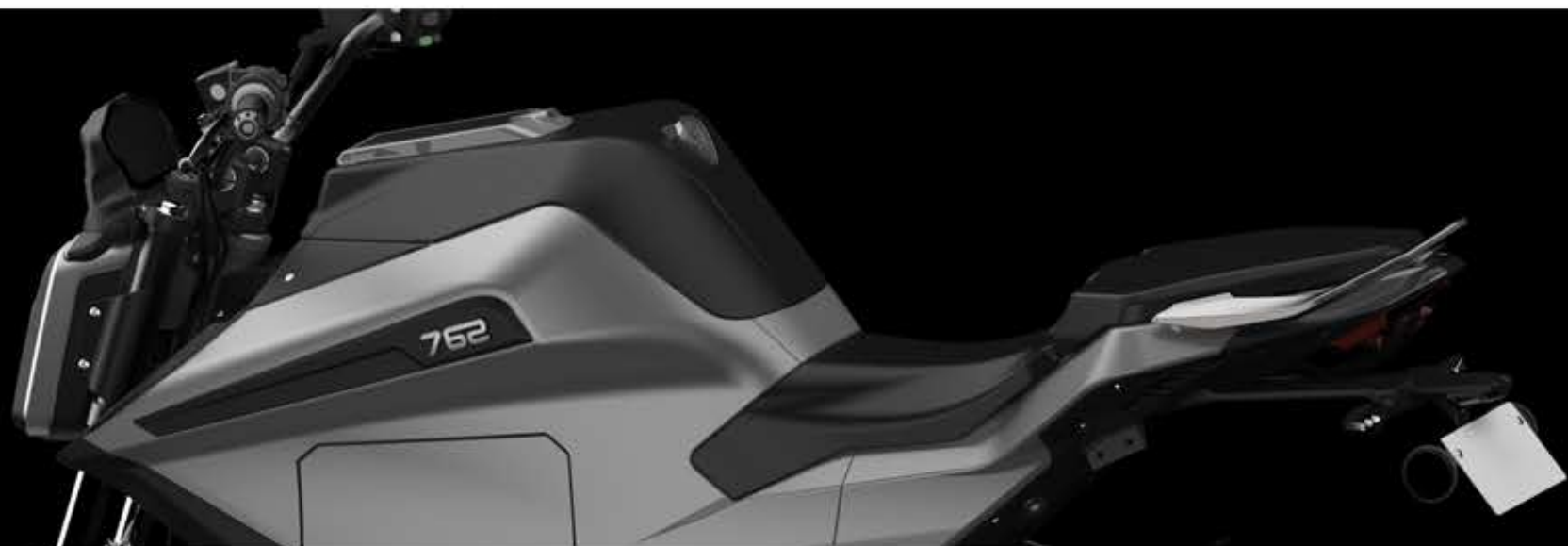







## **LUXURY FOR THE LAYMAN**

Experience luxury on your daily commute with the CSR762 Electric Bike. Merging style and practicality, CSR762 brings opulence to the layman's ride. Glide through city streets effortlessly, as affordable elegance becomes a part of every journey. Redesign your commute and revel in accessible luxury with the CSR762.

**SCAN HERE**  
FOR MORE INFORMATION







**CSR762.COM**

More **POWER** to You

**SVITCH MOTOCORP PVT. LTD.**

A-309, 410 Stellar, Opp. Arista Business Space,  
Sindhu Bhavan Road, Bodakdev, Ahmedabad-380054

+91 63512 72002 ✉ hello@csr762.com

🌐 www.csr762.com